



APPLICATION:

Cable Trunking

ID:

CFS-FS: 09

INFORMATION:

- Not to scale
- All units are in millimetres
- Tested according EN 1366-3
- Classification No. 23581B

CFS-FS M Flexible Seal

REV:

DATE:

02

02/2025

Fire Rating up to EI 60

Page 1/1

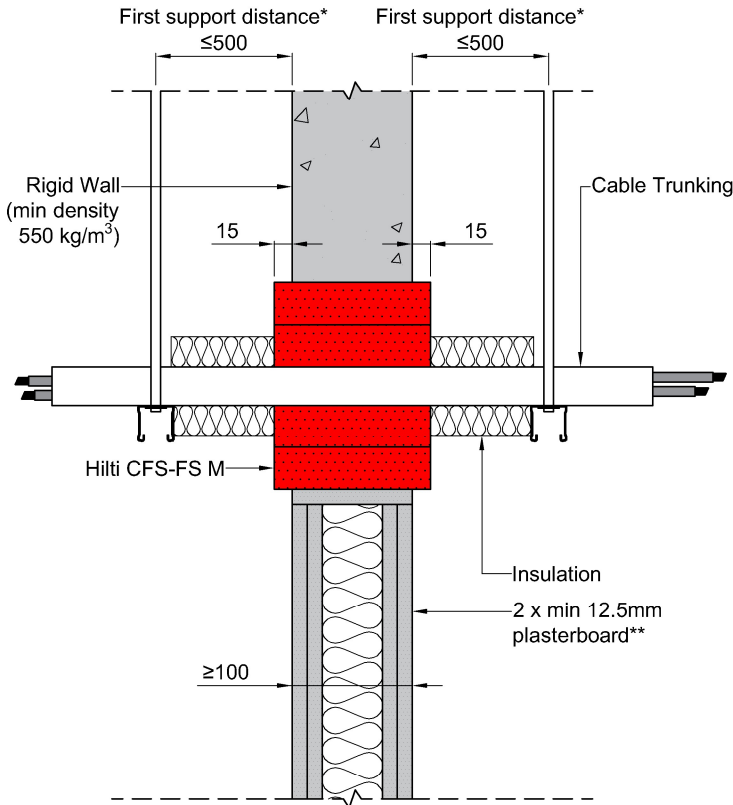

Acoustics rating: $R_w = 50$

Maximum opening dimensions: 1200x500mm. For blank openings see approval documents.

*First support and ancillary products should be capable of achieving the same fire performance as the seal and supporting structure.

**Comprising timber or steel studs. Wall construction itself has been classified according to EN 13501-2.

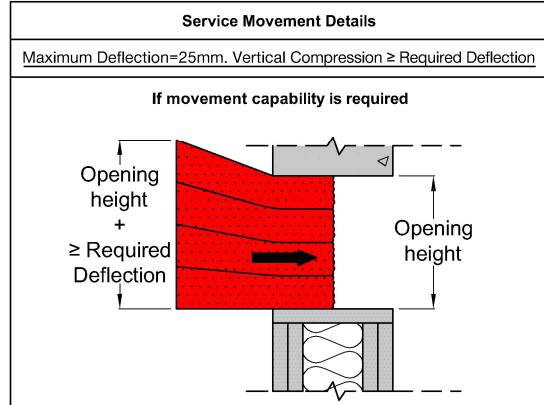

Ref.	Service Type (See service standard detail for more specific information)	Distance (mm) [†]
b ₁	To edge of opening	≥70 ^{††}
b ₂	To side of opening	≥0 ^{††}
b ₃	To top of opening	≥35 ^{††}
C ₁	To metal pipe w/ mineral wool insulation	≥0
C ₂	To metal pipe w/ combustible insulation	≥30
C ₃	To cables/cable bundle/cable carrier	≥30
C ₄	To cable trunking w/ mineral wool insulation	≥0
C ₅	To combustible plastic pipe w/ Hilti CFS-B	≥0
C ₆	To MLC (Aluminium composite) pipe w/ or w/o insulation	≥50
C ₇	To rectangular PVC Duct w/ Hilti CFS-B	≥0
C ₈	To ClimaSplit bundle	≥50
C ₉	To CPVC or TracPipe®	≥30
C ₁₀	To combustible plastic pipe & conduit w/o addn. protection	≥50
C ₁₁	To conduit w/ Hilti CFS-B	≥0

[†]All distance values can be horizontal, vertical or diagonal.
^{††}b₁, b₂, b₃ = 0mm if no movement is required.

Cable Trunking				
Material	Max Dimensions (W x H) [mm]	Type of Insulation	Insulation Thickness Range; Type (Length) [mm]	Classification
Cable Trunking Metal	Up to 150 x 150 [‡]	Rockwool® DuctWrap	25; LI (420)	EI 60 (U/U)
Cables	d ≤ 80 [‡] †	N/A	N/A	EI 60
Note: Fill empty cross sectional area in cable trunking with Hilti CFS-FS with depth of 130 mm				
‡Max Cross Section area of 22,500 mm ²				
† Max 28mm for coaxial cables & max 24mm for non-sheathed cables				

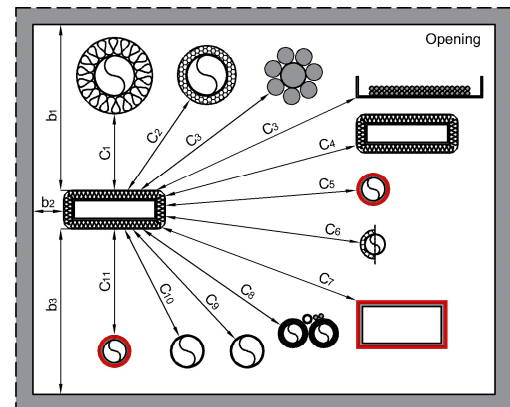

- The application limits on this detail are for guidance purposes only. For more detailed information based on the full range of available test results please contact the Hilti Technical Advisory Service.
- The product and application has been assessed as a minimum to the BS 476 standard. It may have additional European and worldwide testing. Please contact Hilti for further information.
- All installations should be carried out in accordance with Hilti's installation instructions and by competent & experienced installers using Hilti branded products.
- All services are to be correctly and adequately supported to prevent collapse and distortion.

Hilti (Gt. Britain) Limited | No 1, Circle Square | 3 Symphony Park | Manchester | M1 7FS

Freephone: 0800 886 100 | Website: www.hilti.co.uk

LEGAL NOTICE: This template contains Hilti Intellectual Property which is legally protected, including Community registration of Hilti trademarks. For use only by Hilti customers and in conjunction with Hilti products. No third party use/products is authorised and breaches Hilti's intellectual property rights. Hilti accepts no responsibility for unauthorized use and reserves all rights to take legal action to enforce its rights in law.